

Transformer Breathers

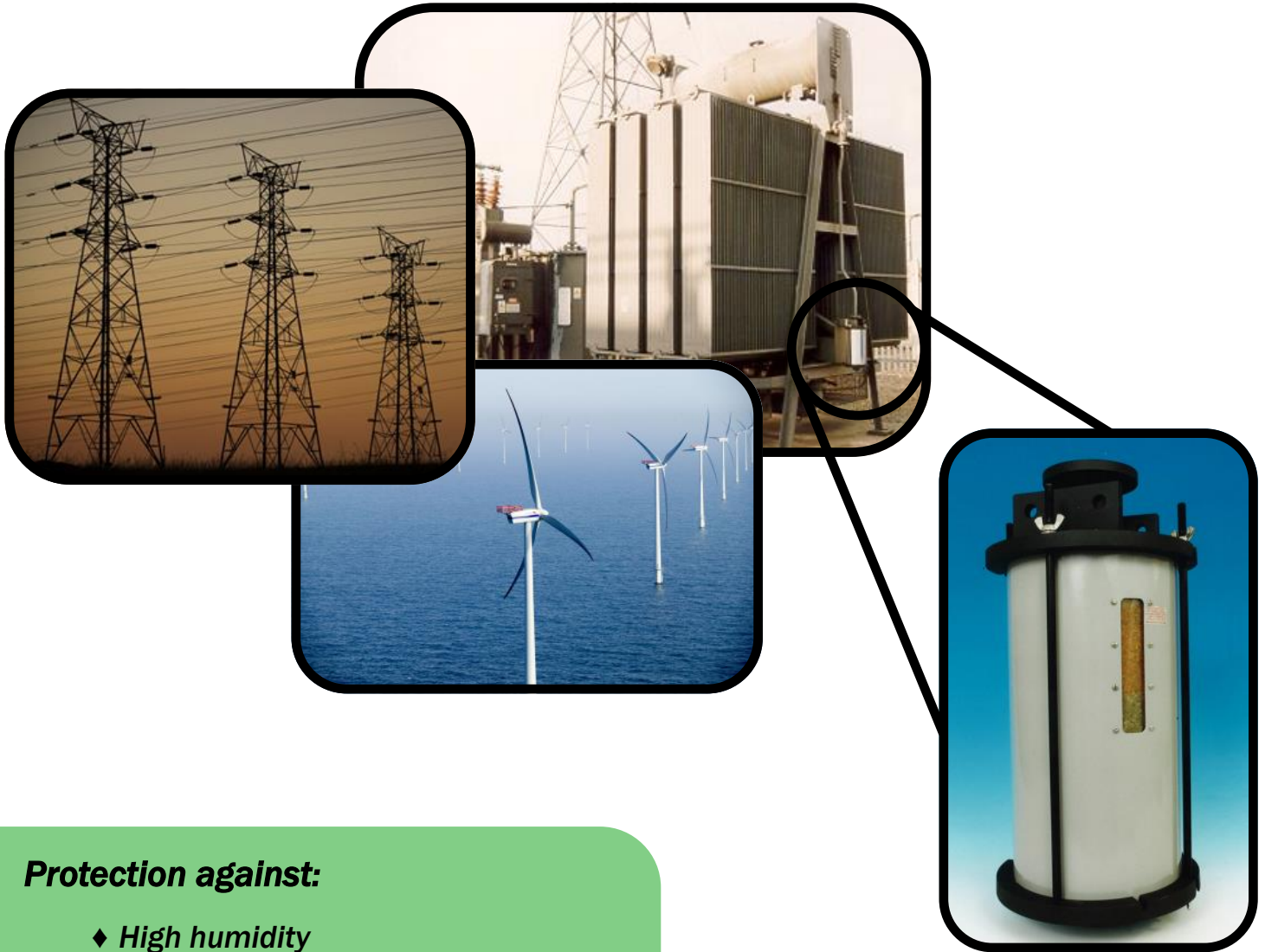

Protection against:

- ◆ *High humidity*
- ◆ *Water condensation*
- ◆ *Pressure variations*
- ◆ *Dielectric loss*
- ◆ *Mould growth*
- ◆ *Outgassing*

Key Technical Features

- High performance plastic or metal construction
- Simple installation
- ISO9001/2008 design approved
- Suitable for 1250 kVA to 750 mVA Transformers
- Low dusting beaded ENVIROGEL adsorbent
- Up to 25% adsorption capacity
- Definitive colour change saturation indication
- IP65 rating
- Operating temperature range -50°C to $+70^{\circ}\text{C}$
- Vandal proof
- Weather resistant
- All round visual saturation indicator



Size R Transformer Breather

Typical Electrical Breakdown in Transformers

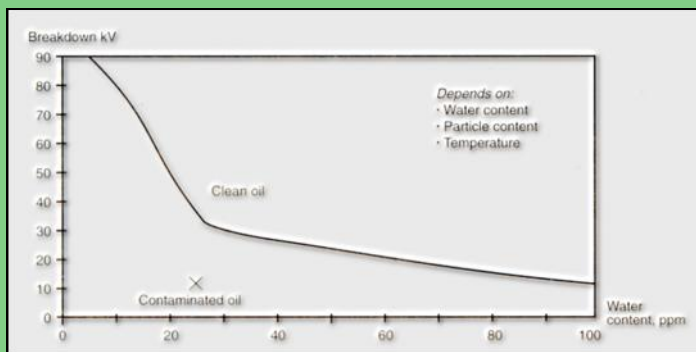

The insulation value of oil can deteriorate dramatically as it becomes contaminated with water.

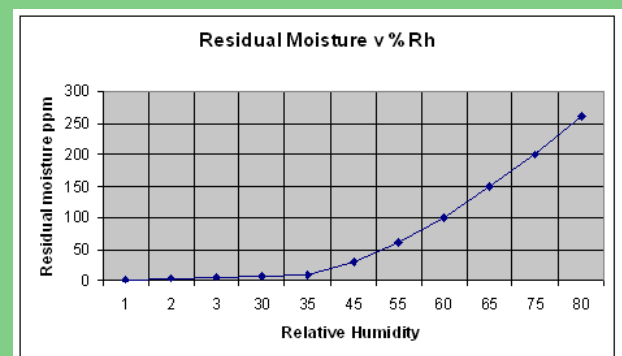

Water content of oil increases as it is exposed to high relative humidity

Rechargeable Transformer Breathers



V, W Transformer Breathers

BROWNELL Transformer Breathers provide clear visibility of the ENVIROGEL through a shatter-proof, UV stabilised polycarbonate cylinder or window.

Two-way, low pressure valves are fitted in the base of the breather, to ensure that atmospheric air enters the desiccant charge when a negative pressure differential occurs within the transformer being protected.

BROWNELL Transformer Breathers are filled with ENVIROGEL, self-indicating desiccant.

The ENVIROGEL is orange in colour when active, turning green when saturated. This allows a visible assessment of the condition of the ENVIROGEL. Various sizes and packs of ENVIROGEL are available for refilling the Transformer Breathers.

BROWNELL have more than 60 years experience in the design, manufacture and testing of types of humidity control equipment and moisture measuring instruments. Please contact our Technical Services Division for further information.



Two Toggle 701 & 702 Transformer Breathers

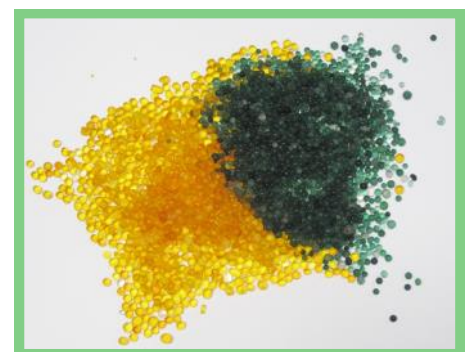

The ENVIROGEL: orange in colour when active, turning green when saturated



Sizes R, R1 & R2

The top pipe connector (3/4" Female Pipe Thread) is also the filling and emptying point. The beaded, self-indicating ENVIROGEL should be replaced once the colour has changed from orange to green, as indicated on the label attached to the breather. All threads conform to BS21 and ISO7-1. Full installation and maintenance instructions are supplied with each BROWNELL Transformer Breather.

Size	Max. Oil Contents	Weight of Desiccant	Overall Length (A)	Overall Diameter (B)
R	1500 Litres	0.60 Kg	158mm	108mm
R1	3000 Litres	1.20 Kg	250mm	108mm
R2	4750 Litres	1.90 Kg	352mm	108mm

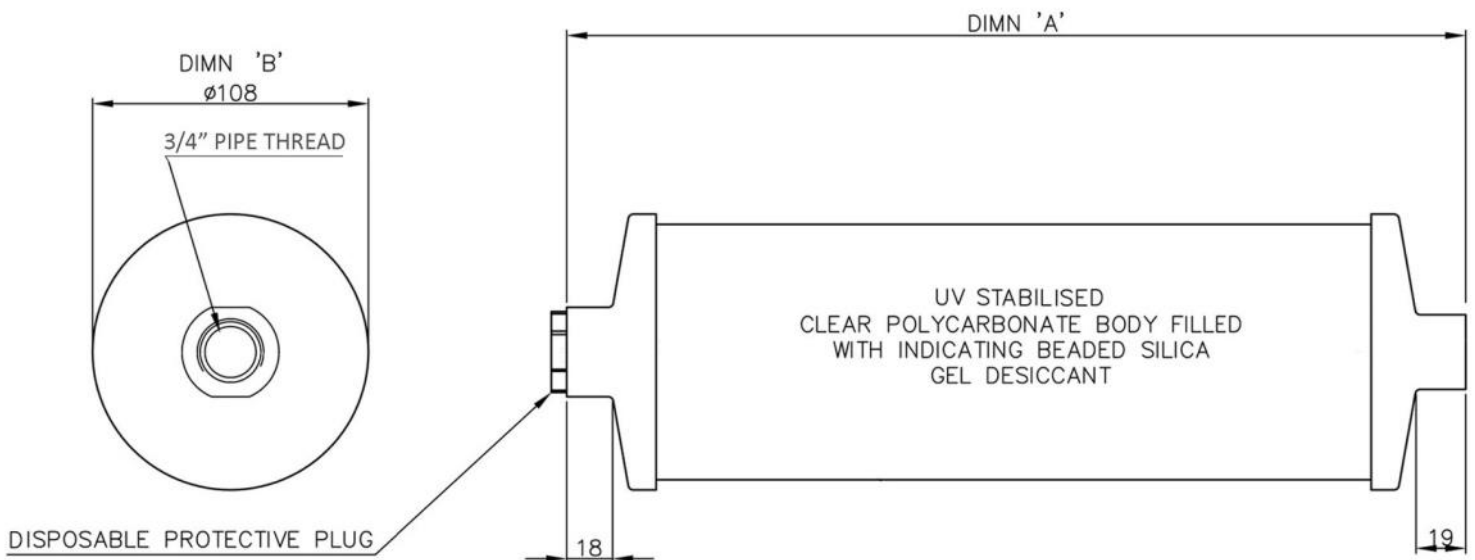

Sizes R, R1 & R2

Sizes V, W, X, Y & Z

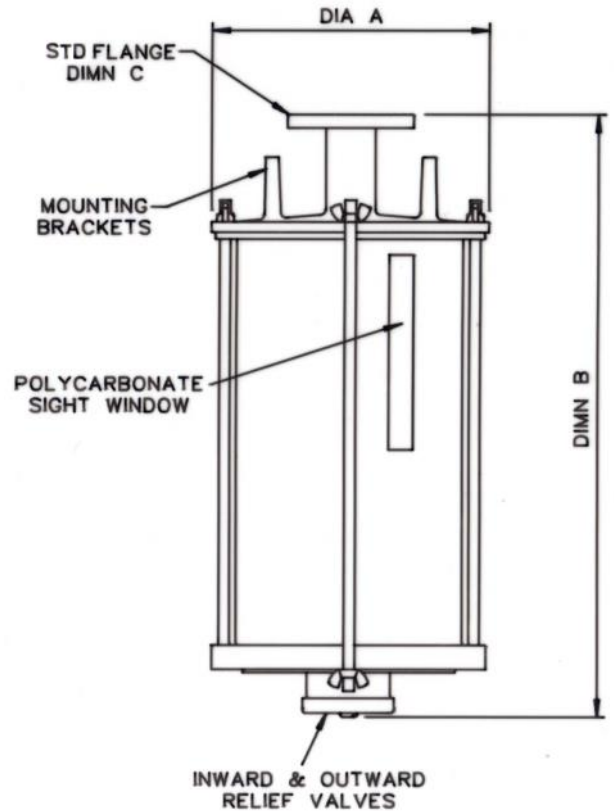

These Transformer Breathers are connected either by a flange or pipe thread connection. Mounting brackets on the top plate provide additional support for the Transformer Breather. Two-way, low pressure valves are fitted in the base plate of the breather to ensure that the atmospheric air enters the desiccant when a negative pressure differential occurs within the Transformer being protected.

Size 'V, W & X' Transformer Breather has a 3/4" Female Pipe Thread. Size 'Y & Z' Transformer Breather has a 1" Female Pipe Thread.

All threads conform to BS21 and ISO7-1.

BROWNELL Transformer Breathers are also available as double and triple units. Please contact our Technical Services Division for details of the YY, ZZ, YYY & ZZZ assemblies.

Sizes V, W, X, Y & Z

Size	Overall Diameter (A)	Overall Length (B)	Standard Flange (C)	Weight of Desiccant	Max. Oil Contents
V	255mm	375mm	1 " B.S.T.D.	5.0 Kg	11,350 Litres
W	255mm	555mm	1 " B.S.T.D.	10.0 Kg	22,700 Litres
X	255mm	735mm	1 " B.S.T.D.	14.5 Kg	34,050 Litres
Y	355mm	485mm	1 " B.S.T.D.	17.5 Kg	45,450 Litres
Z	355mm	645mm	1 " B.S.T.D.	27.3 Kg	68,150 Litres



Mark 7 Transformer Breathers

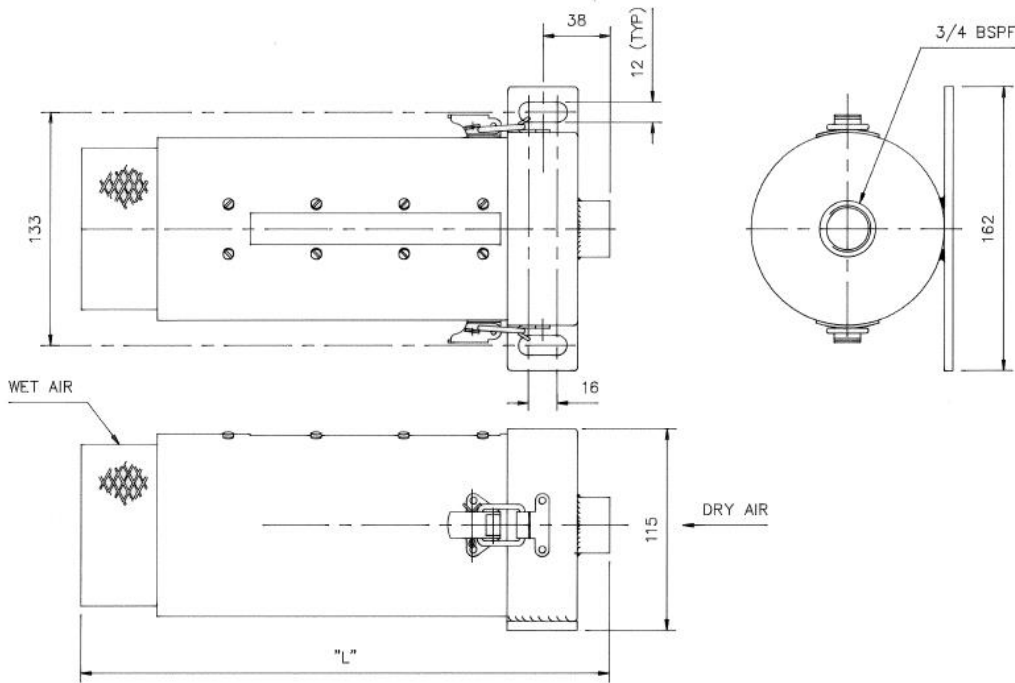

702 Transformer Breather

Mark 7 Transformer Breathers were introduced to meet the additional robustness necessary for the efficient protection of equipment operating under high mechanical stress i.e. the braking systems on trains. Fabricated from welded mild steel which is phosphate conversion and powder coated. Mark 7 Transformer Breathers will withstand the bump, vibration and shock parameters found in electric traction and similar vehicles.

The BROWNELL Mark 7 Transformer Breathers are fitted with oil-seal bowls and are re-filled with Envirogel desiccant. The only maintenance action required is periodic inspection of the oil level and replacement of the spent desiccant. The beaded desiccant has a much higher dust attrition resistance when compared with the standard granular material.

Model No.	Fixing Centers (mm)	Overall Height " L" (mm)	Desiccant Weight (Kg)	Equipment Oil Content (Litres)
701	133	188	0.75	550
702	133	302	1.20	880
703	133	473	2.50	1,850

Quick Change

- ◆ ENVIROGEL cartridges can be refilled, replaced or reactivated
- ◆ Rapid cartridge replacement
- ◆ No special tools required
- ◆ Minimum downtime and maintenance
- ◆ Ideal for planned maintenance cycles



Transformer Breathers can be changed in a matter of minutes with Brownell's replacement cartridges. (Size W illustrated)

FAQs

Q: Can I fit a Transformer Breather, which has a larger ENVIROGEL capacity than my existing Transformer Breather?

A: Yes, for example you can use a Size R1 Transformer Breather to replace an R type which will significantly increase the time between ENVIROGEL maintenance.

Q: Are there any specific safety considerations when handling Transformer Breathers and ENVIROGEL?

A: We recommend when handling ENVIROGEL, suitable precautions are taken (as with any potentiality dust generating material) an approved respiratory mask is used.

Q: What is the recommended method for disposing of used ENVIROGEL?

A: We suggest that used ENVIROGEL is disposed of at a registered landfill site in accordance with local authority regulations.

Q: How can I reactive saturated ENVIROGEL?

A: Following the safety procedures for handling ENVIROGEL. Heating the ENVIROGEL for 3-4 hours at 95°C will recover 95% of the adsorption capacity.

Data to be used in selection of
Transformer Breather Units



Type	Max. Oil Contents (Litres)	Approximate Transformer Rating (MVA)	Max. Air Space Volume (Litres)	Approximate Daily Breathing Rate (Litres)	Max. Air Volume Before Recharge (Litres)	Estimated Effective Cycle Time (Days)
R	1,500	<1.25	230	15	6,000	400
R1	3,000	3	500	30	12,000	400
R2	4,750	6	1,100	55	20,000	400
V	11,350	9	2,400	140	45,450	320
W	22,700	30	4,800	280	90,900	320
X	34,050	60	7,250	420	136,500	320
Y	45,450	100	9,685	570	181,800	320
Z	68,150	180	14,500	840	272,700	320
YY	90,900	240	19,370	1,140	363,600	320
ZZ	136,360	500	29,000	1,680	545,400	320
YYY	136,360	500	29,055	1,700	545,400	320
ZZZ	204,550	750	38,750	2,280	818,100	360

Guidance Information only.

ENVIROGEL Reactivation

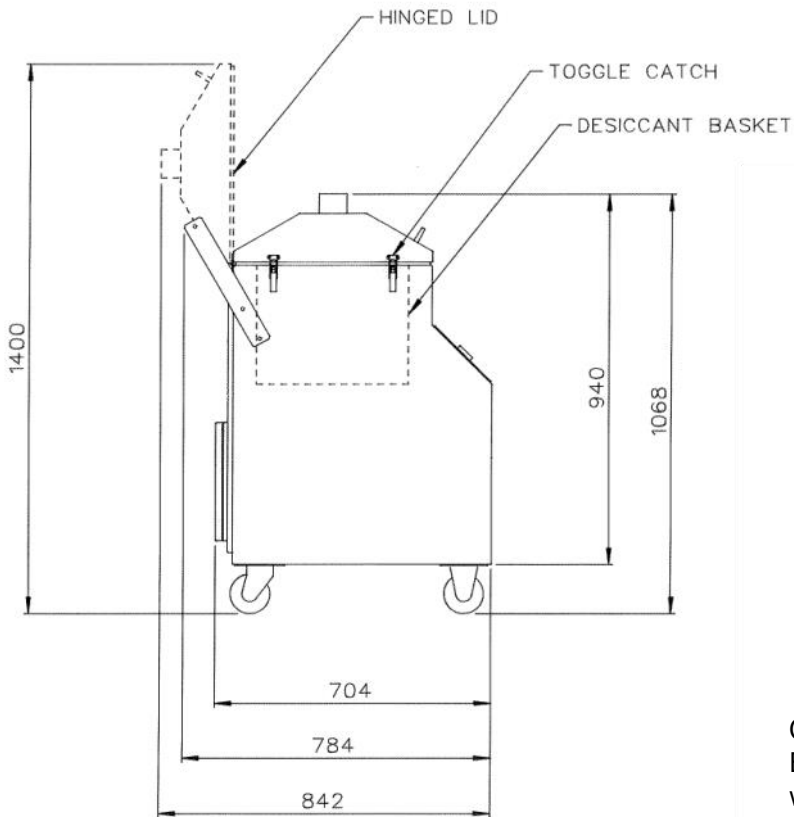

Reactivation Unit Model No. BLE1005/04

One of the principal reasons for the use of indicating ENVIROGEL is its ability to release adsorbed moisture when heated to a temperature of 95°C. This means it can be recovered and used.

The Reactivation Unit is a purpose designed equipment to do that. It is operated from a standard mains electricity outlet to power (240V 50Hz) the three kilo-watt heaters. A forced air circulation ensures the evaporating moisture is transported from the desiccant.

Key Features

- ◆ Precise reactivation management
- ◆ Removable desiccant holder
- ◆ Temperature monitor indicator
- ◆ Temperature control
- ◆ Wheeled castors for easy placement
- ◆ Elapsed time indicator
- ◆ Max. Silica Gel capacity of 25kg
- ◆ Fume duct piping

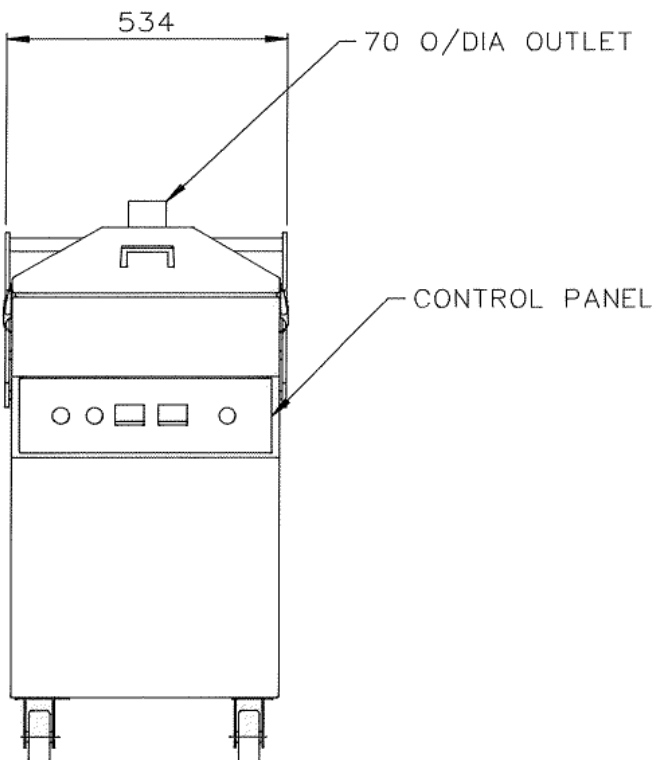

Size Matters

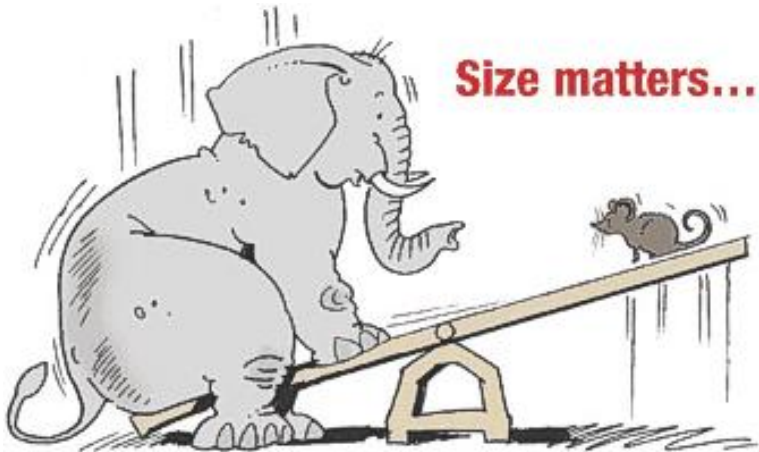

**Doubling your desiccant life coupled with reduced maintenance
DOESN'T MEAN TWICE THE COST!**



Size R can be replaced
with **Size R1**



Size V can be replaced
with **Size W**



Size Y can be replaced
with **Size Z**

Switchgear SF6

Brownell limited offer a range of desiccant solutions to combat the problems of moisture within SF6 filled High Voltage switchgear enclosures.

Sulphur hexafluoride (SF6) is used as an insulating gas in transmission and distribution equipment such as switchgear and circuit breakers.

In order to maintain SF6 insulation properties and to reduce the formation of unwanted secondary decomposition products, the amount of water vapour in the gas insulated system (GIS) should be kept to a minimum.

If moisture levels are not kept to a minimum then formation of acidic by-products, such as Hydrogen fluoride, Sulphur dioxide, Sulphur fluoride & Thionyl fluoride can be generated.

This reaction may yield hydrofluoric acid. Hydrofluoric acid is extremely corrosive and will react with electrical equipment components.

Moisture limit recommendations vary between equipment manufacturers but typically values of -45°C to -25°C dewpoint (atmospheric).

In order to maintain these low moisture levels a passive desiccant solution must be included within the cabinet.

Brownell suggests that a large pore molecular sieve (13x) be used as this has the ability to co-adsorb both moisture and arcing by-products.



BLD3717/86

High Voltage Enclosures

High Voltage motor protection desiccators provide protection against corrosion, dampness and contamination in electrical, high voltage motors and switchgear.

These desiccators incorporate a humidity which monitors saturation and indicates when desiccant change or cartridge replacement is required.

They are blue when the desiccant is dry and turn pink when the maximum amount of moisture has been adsorbed.



BLD1099



BLD1078



BLD6088

ENVIROGEL DESICCANT

BROWNELL Transformer Breathers are filled with Envirogel Desiccant, which changes colour from orange to green as it becomes saturated with water vapour.

Brownell Transformer Breathers are designed to enable the easy and quick replacement of the desiccant charge. When the colour change from orange to green has reached the level showed on the label, charge should be replaced. Now that old type oil-seal has been replaced by inward and outward relief valves, the replacement of the desiccant charge is the only maintenance activity necessary.



Brownell supply sealed replacement charges of Envirogel desiccant in the following sizes:

Part No	Refill Qty	Packaging
BL/D6331/01	0.5kg	Metal Foil Laminate Pouch
BL/D6331/02	1kg	Metal Foil Laminate Pouch
BL/D6331/03	3kg	HDPE Resealable Bottle
BL/D11845	5kg	HDPE Resealable Bottle
BL/D10736	10kg	HDPE Resealable Bottle
BL/D6331/05	12.5kg	HDPE Resealable Bucket
BL/D6331/06	25kg	HDPE Resealable Drum

